

EXPERTISE YOU CAN TRUST

Putting Innovation and Knowledge to Work for You

USA
Des Moines, Iowa
Verona, Missouri
Email: KN.CS@kemin.com

Europe
Veronella, Italy
Herentals, Belgium
Email: CSVeronella@kemin.com
Email: CSHerentals@kemin.com

South America
Várzea, Santa Catarina, Brazil
Indaiatuba SP, Brazil
Email: CS.Nutri@kemin.com

India
Chennai, Tamilnadu, India
Email: KN.CS@kemin.com

China
Shanghai, China
Email: KN.CS@kemin.com

Singapore
Singapore
Email: KN.CS@kemin.com

Australia
Geelong, Victoria, Australia
Email: KN.CS@kemin.com



WWW.KEMIN.COM/PETFOOD

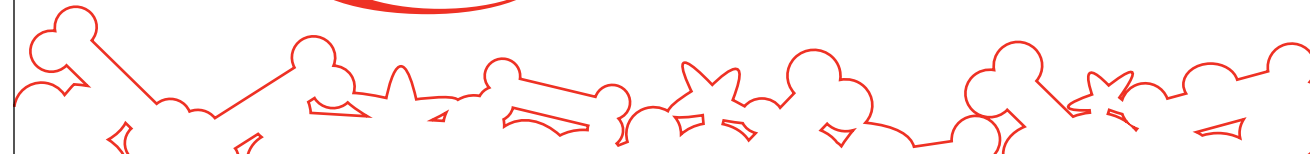

SYNERGISTIC BLEND

The synergies between Kemin's expertise and service capabilities, in all areas of petfood manufacturing, allow us to provide scientific and industry insights to our customers, so they can be as successful as possible.

Kemin takes pride in the fact that many of the world's leading petfood manufacturers and ingredient suppliers trust us to help them with their petfood performance programs. When creating a winning brand, you need a trusted partner that understands how the raw materials, production process and other factors can have an impact on the final product. Changes to a single formula specification can affect everything from diet stability and palatability to nutrient status. Partner with Kemin today to benefit from:

- Specific focus on the petfood industry
- Unique expertise in ingredient and rendering industries
- Tailor-made support and services from area sales and technical teams
- Global product availability from regional manufacturing facilities
- Controlled raw material supply, including vertical integration
- Company-wide focus on quality and food safety
- Culture of innovation and delivering inspired molecular solutions

COLLABORATION

Kemin collaborates with customers to find the best solution to their problems. We are there before, during and after a purchase with additional technical and lab support to verify the performance of our products and provide feedback on what the results mean for your operations.

The nutrinsurance division of Kemin is exclusively focused on providing innovative solutions to the global petfood industry. In addition to being a trusted supplier of superior antioxidant and palatant products, Kemin continues to serve the petfood industry by offering a wide-range of tailored customer support. What really sets Kemin apart is our people – dedicated ingredient and petfood experts are the glue that holds our products and services together, ensuring that our customers can always create winning brands.

QUALITY &
MANUFACTURING
EXCELLENCE

EQUIPMENT
SERVICES

CUSTOMER
LABORATORY
SERVICES

TECHNICAL
SERVICES

COMMITMENT TO CUSTOMERS

QUALITY & MANUFACTURING EXCELLENCE

EQUIPMENT SERVICES

CUSTOMER LABORATORY SERVICES

TECHNICAL SERVICES

QUALITY & MANUFACTURING EXCELLENCE

At Kemin, quality is not just important – it’s a way of life. Kemin continues to look for innovative ways to provide leadership in the advancement of quality initiatives. The Kemin quality promise includes all employees and departments – research and development, manufacturing, quality control, CLS, and others – to pursue a strict set of procedures in their daily activities. Following those procedures assures customers that the products they buy are of the same quality every time they order. The culture of Kemin quality is shared throughout all of our locations around the world. Our state-of-the-art manufacturing facilities maintain multiple quality certifications because, at Kemin, we know consistent manufacturing equals consistent, high-quality results in all parts of the world.

KEMIN QUALITY CERTIFICATIONS:

- FSSC 22000: 2010
- FAMI-QS
- I-SF/SF
- GMA-SAFE
- GMP
- HACCP

KEMIN QUALITY INITIATIVES:

- Central Analytical Laboratory for Target Analytes and Xenobiotics (CALTAX)
- Raw Material Risk Assessments

QUALITY AT KEMIN

“Quality at Kemin means we make promises to our customers every day to deliver efficacious, safe ingredients. We fulfill this promise by incorporating quality into every aspect of our business – starting with innovative product development, continuing with Good Manufacturing Practices, and extending until the final product is consumed by the end-user.”

–Dr. Christopher E. Nelson

QUALITY & MANUFACTURING EXCELLENCE

EQUIPMENT SERVICES

CUSTOMER LABORATORY SERVICES

TECHNICAL SERVICES

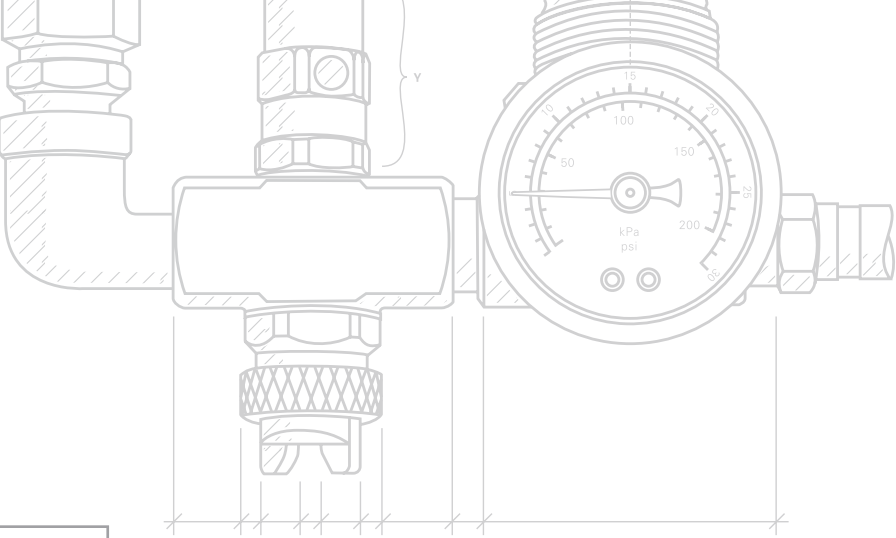

EQUIPMENT SERVICES

Whether it's an antioxidant or a palatant, the effective use of an ingredient can only be as good as its proper application and distribution. Kemin understands that every facility is different, so we are committed to providing customized equipment, training and education to ensure your performance goals are met. Our experts are available to collaborate with you on your specific equipments needs. We can assist with the equipment at your facilities or at your supplier's facilities.

CORNERSTONES

System design, installation, calibration, maintenance and post-sales support are the cornerstones of our equipment service offerings.

To provide value, our team of highly qualified engineers and technical experts partner with customers to develop state-of-the-art application equipment that is designed to meet each unique need. Our equipment experts will help:

- Complete a comprehensive site survey
- Assist in equipment selection and calibration
- Advise on product application rates, locations and process development
- Respond quickly to troubleshoot and address any issues

EQUIPMENT SERVICES

CUSTOMER LABORATORY SERVICES

TECHNICAL SERVICES

OUR APPROACH

CUSTOMER LABORATORY SERVICES

Kemin utilizes a multi-analysis approach—we utilize more than one test result to evaluate the issue.

CONTRIBUTING TO CUSTOMER SUCCESS

The Kemin Customer Laboratory Services (CLS) team provides dedicated analytical support throughout all phases of the petfood manufacturing process. By partnering with customers to analyze the integrity of their supply chains, we are able to understand the influences that various petfood ingredients have on the stability of your final product—keeping it safe, fresh and nutritious. Our industry-leading throughput and turnaround times, as well as our validated equipment and methods, allow us to meet and exceed your overall business goals. CLS provides the laboratory support services you need to meet your end product specifications.

- Vendor validation with raw material quality assessment
- Application rate and equipment verification to optimize Kemin product use
- Ingredient and product trouble shooting
- New ingredient and product development assistance
- Analytical support, applied research, and quality control support
- Advanced method development

TECHNICAL SERVICES

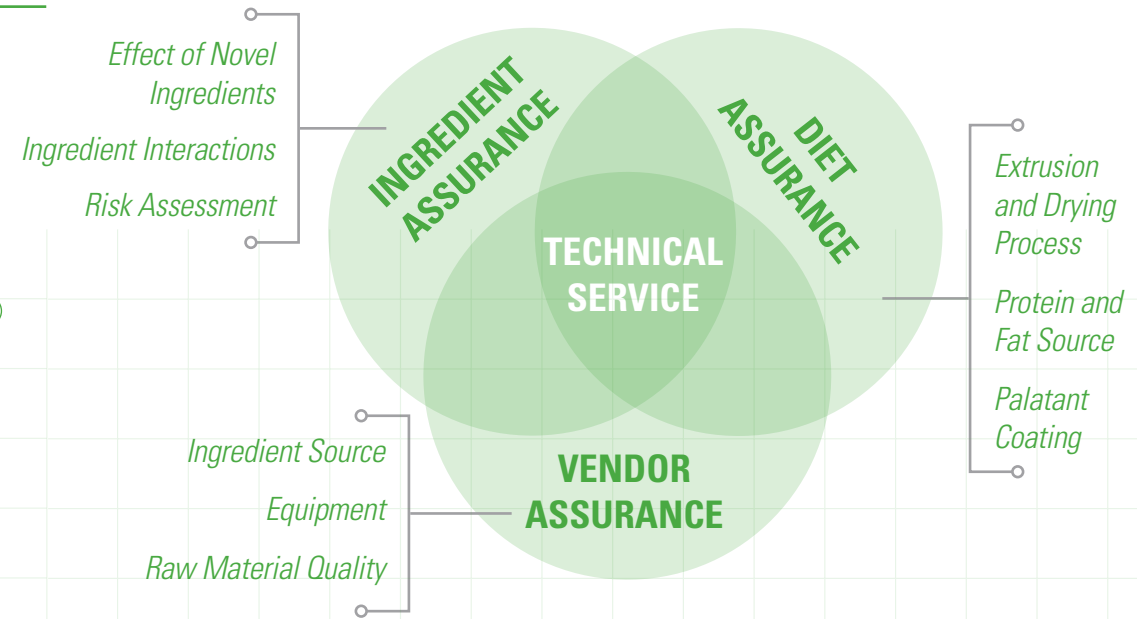
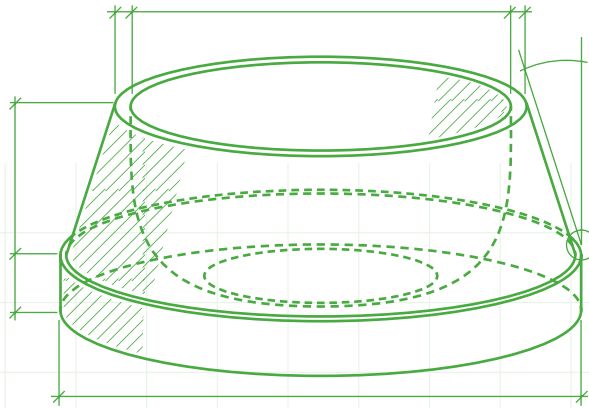

The stability and palatability of pet food depends on many factors throughout the entire ingredient supply chain and petfood manufacturing process. The Kemin team will support your business with our dedicated technical service staff to protect and enhance the value of your ingredients and petfood products.

Our Technical Service team uses their technical expertise and problem solving skills to uncover the source of a problem and then develop a tailored solution. They are the common thread, or the customer liaison, that weaves all of our services together ensuring that each customer's experience is unique and tailored to their specific issue.

In addition to equipment and CLS capabilities, our technical service staff will assist you in answering questions such as:

- How do I keep up with the changing market landscape, trends and availability of raw materials and ingredients?
- What impact will new ingredients have on the stability and palatability of my diet formulations?
- When is the best time to add an antioxidant? Where in the manufacturing process? How do I know I'm using the correct inclusion rate of an antioxidant or palatant?
- Does my final diet meet all my shelf-life and flavor expectations?
- Will switching from one ingredient supplier to another affect my diet performance?

Trust the Kemin team to answer all of your ingredient, diet or vendor questions - contact a technical service manager today!